

Modular automated media packaging line PRESTO

Presto

- Consists of 5 modules
- Can work semi- and also fully automatically
- Packs up to 30 cases per minute
- Stand-alone packaging system
- Increases operators efficiency up to 500%



About the Presto line

The Presto Line of automated stand-alone packaging systems is a highly efficient modular solution to automate all phases of media packaging.

Each module can be used independently in a semi automatic capacity, or all modules can be utilized in conjunction to fully automate the entire packaging line. A complete fully automated line consists of five modules. The modules are:

Case Opener and Presenter, Slipsheet Inserter, Disc Placer, Booklet Placer, and finally a Case Closer Module.

The Presto Title Sheet Inserter

The Presto Inserter Inserts title sheets into the cases. Up to 600 title sheets are loaded into the Inserter Hopper.

Cases are fed into the inserter one title sheet is loaded under the clear film of each case prior to ejecting cases from the side of the system.

The cases can be fed in a semi automatic capacity by an operator, or in a fully automatic capacity by the Case Feeder Module.

The Presto Case Feeder

The Case Feeder can be positioned in line with the Presto Inserter to automatically open and insert each case into the Presto Inserter.

Closed cases are loaded into a hopper. The system opens each case and inserts them into the Presto Inserter automatically. An extended in-feed hopper accommodates approximately 200 cases at a time.

Presto Disc Placer

Discs are loaded on industry standard spindles into the Disc Placer Module. Cases dropped onto the Presto Disc Placer conveyor are indexed to the disc placing position where one disc is placed into each case in any of the standard hub positions.

Multiple Presto Disc Placers can be positioned in line to place any number of discs into each case.

The Presto Disc Placer can also be used to place discs in CD Jewel Cases, Cardboard DigiPack Trays.

PRESTO

Modular automated media packaging line

Presto

Specifications

Formats compatibility

Virtually all Amaray: Slimline, Standard, Jumbo, Blu-ray, HD-DVD, DS Amaray cases

Module speed

Up to 30 cases per minute

Connectivity

Electric, Regular Outlet 110 or 220 V Pneumatic, 90 psi

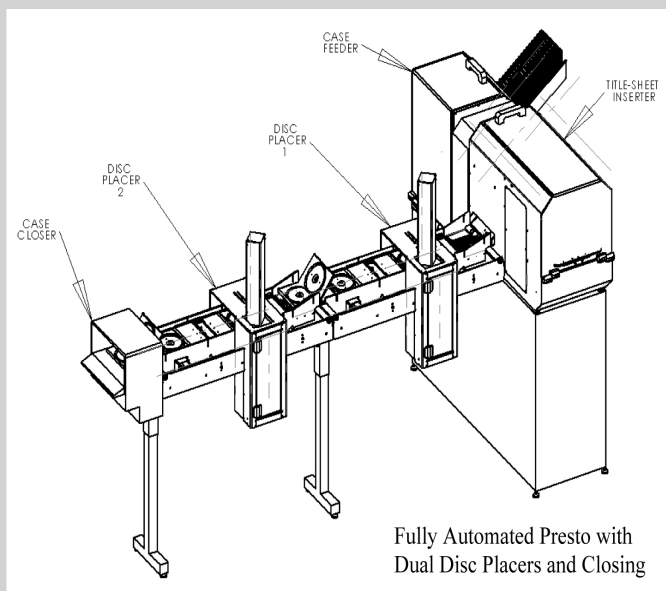

JMV Robotique Desktop packaging solutions

The speed wrap series is part of JMV Robotique range of desktop packaging solutions of on-demand CDs and DVDs. Other equipment in this range includes:

LAB500	Universal labeller
LAB120	Disc labeller
MEP120	CD/DVD sleeve
BCD100	Semi-automatic CD packer
DVD100	Mounting jig for DVD cases

The Presto Disc Placer and Presto Case Closer also supports CD Jewel Cases, Super Jewel cases and paperboard Digipacks.

Modules

- Presto Title Sheet Inserter
- Presto Case Closer
- Presto Booklet / Coupon Inserter
- Presto Case Feeder
- Presto Disc Placer

Warranty

12 months back to base, all parts and labour included.